



# INSTRUCTION GUIDE

Amina Technologies Ltd

## Model: AIWX Series

AIW1X, AIW2X, AIW3X, AIW4X, AIW5X



Amina Technologies Ltd  
Cirrus House  
Glebe Road  
Huntingdon  
Cambridgeshire  
PE29 7DX

T+44(0)1480 354390

F+44(0)1480 356564

E [inspired@amina.co.uk](mailto:inspired@amina.co.uk)

W [www.amina.co.uk](http://www.amina.co.uk)

# Carton Contents:

With the purchase of any Amina AIW In-Wall Loudspeaker

- four white plastic mounting lugs to every one Amina® In-Wall Loudspeaker
- One Amina® In Line Protection unit (APU2) [one APU2 two channel unit protects two loudspeakers]

## AIW1X Carton:



- 1 x AIW1X panel



## AIW3X Carton:



- 1 x AIW3X panel



## AIW5X Carton:



- 1 x AIW5X panel



## AIW1XPAIR carton:

- 2 X AIW1X
- 1 X APU2
- 8 x Plastic mounting lugs

## AIW3XPAIR carton:

- 2 X AIW3X
- 1 X APU2
- 8 x Plastic mounting lugs

## AIW5XPAIR carton:

- 2 X AIW5X
- 1 X APU2
- 8 x Plastic mounting lugs

# Contents

<b>Thank you for purchasing an Amina Technologies product</b>	<b>04 - 05</b>
Safety Warning & Carton details	
Introduction	
<b>Amina versus ordinary speakers</b>	<b>06 - 07</b>
Amina SoundUnseen In-Wall Characteristics	
Sound radiates in all directions	
The sound pressure level fall off is more gradual off axis and in a bounded space	
Radiated sound energy is random, diffused and highly dispersed	
Visual appearance can be matched to the surrounding decoration	
<b>Amina bespoke service</b>	<b>08</b>
<b>Applications</b>	<b>08</b>
<b>Product positioning &amp; quantity requirements (Home Installation)</b>	<b>08 - 09</b>
<b>Product positioning &amp; quantity requirements (Commercial Installation)</b>	<b>10 - 11</b>
<b>Sound Transmission</b>	<b>11</b>
<b>Installing Your Amina SoundUnseen In-Wall Panel Loudspeaker</b>	<b>12 - 13</b>
<b>Connecting to your amplifier/audio system</b>	<b>14 - 15</b>
Amina In-Line protection unit (APU2)	
Typical home theatre set-up	
<b>Optional Accessories</b>	<b>16</b>
Amina Stud Wall Backbox	
Amina Solid Wall Backbox	
100v/70v line options available	
<b>Installation Fault Finding Guide</b>	<b>17</b>
No sound output	
Distortion, buzzing or rattling sounds at modest volume levels	
Sound output is very low	
Distortion at high volume levels	
Feedback occurs easily with open live microphone channels	
<b>Further Details &amp; Specifications</b>	<b>18 - 19</b>
Maintenance, Cleaning and Decoration	
Warranty	
Reliability	
Removal	
Specifications	



# Thank you for purchasing an Amina® Technologies product

**We recommend that you spend a few minutes reading this guide, which has been written to help you get the most from your purchase.**

**Safety Warning:** Never connect this product directly to the mains electrical supply!

**Fragile Electronic Equipment:** This Amina® product is a sensitive piece of electronic equipment, please take great care of it. Damage will occur with harsh treatment.

**Unpacking:** Unpack your Amina® SoundUnseen® Plaster-in-Wall loudspeaker (abbreviated 'In-Wall Loudspeaker' in this document) with care. Visually check the product and, in the event of transit damage, immediately inform your supplier. We suggest retaining your packaging to transport the product safely at a later date.

## Contents:

This carton contains:

- four white plastic mounting lugs to every one Amina® In-Wall Loudspeaker
- One Amina® In-Line Protection unit (APU2) – [one APU2 two channel unit protects two loudspeakers]

**Please Note:** In order to protect this device from too much low frequency audio energy and excessive power inputs and to validate your warranty, you must use the supplied Amina® In-Line Protection Unit (APU2). For advice on connecting this unit please see page 14.



APU Protection Unit

**Once Plastered into position:** Please avoid pushing the wall or ceiling surface immediately in front of this In-wall loudspeaker. Excessive excursion, whilst unlikely to damage the loudspeaker, may lead to cracking of the plaster around the perimeter of the product.



## Introduction:

The Amina® SoundUnseen® technology utilises a revolutionary 'diffuse source' vibrating soundboard technique (like that of a traditional acoustic musical instrument) to reproduce high quality, high clarity, highly intelligible sound, even in acoustically reflective areas where conventional cone 'piston-like' loudspeaker systems generally under perform.

Don't worry, these surface vibrations are absolutely tiny and cannot be seen with the naked eye, but they will be detected by our more sensitive touch sense.

The majority of the sound energy generated by this 'diffuse source' vibrating soundboard technique is incoherent (or non-phase related), whereas the conventional 'point source' loudspeaker generates a coherent (or phase related) sound wave. Whilst this diffuse energy is unseen and its effects are not immediately obvious, this is important in acoustically 'live' spaces and in the way our brains interpret sound (the complex science of psychoacoustics).

Please note that this In-wall loudspeaker product by itself is not a direct replacement for a conventional full range loudspeaker system. In 'hi-fi' and home theatre listening applications a low frequency driver or sub bass may be required to 'enhance' the bottom end of the frequency spectrum. This is easily done as the direction of such low frequencies are not detected by the human ear, allowing such a device to be placed in the most convenient and unobtrusive of locations. For general background music listening and voice reproduction, this product is generally sufficient to be used alone.



### Harrogate House:

Amina In-wall Loudspeaker Panels were installed in this living space to be used with the television and surround sound system

# Amina® versus ordinary speakers:

## Amina® SoundUnseen® Characteristics:

Before installation you should be aware of the basic characteristics of the Amina® SoundUnseen® 'diffuse source' technology. This will help you to get the best results from the product and enable long term, reliable operation in your chosen application.

### 1 Sound radiates in all directions:

Sound dispersion from an Amina® SoundUnseen® 'diffuse source' product is generally spherical in shape across most of the frequencies it reproduces. The positioning of the product is therefore much less critical than with conventional 'point source', inherently directional, cone loudspeakers. There is no need to angle this product to a specific direction. Its height or position within the room is far less relevant and can be placed in any orientation or plane.

Typical Polar plot of an Amina Diffuse Source Loudspeaker

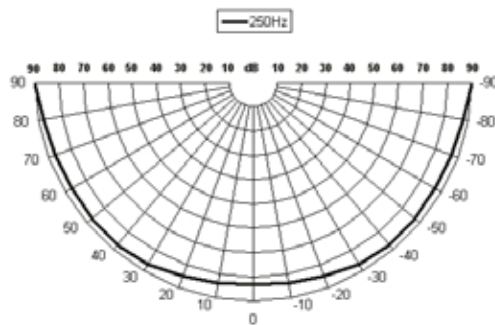

250Hz: Lower midrange

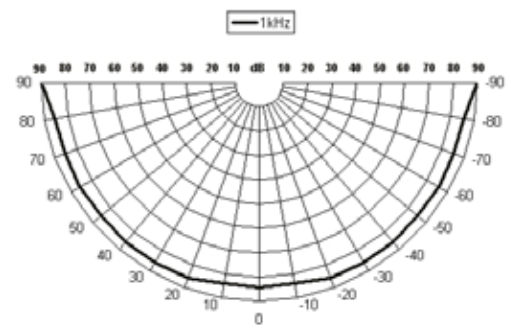

1KHz: Upper midrange

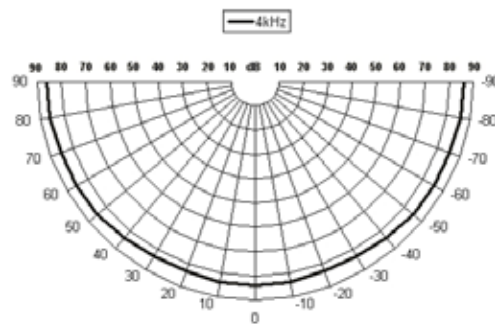

4KHz: Lower Treble

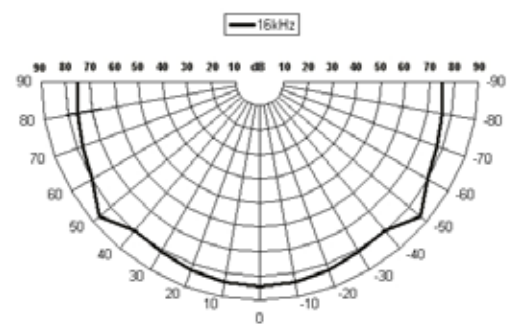

16KHz: Upper Treble

## 2 The Sound pressure level fall off is more gradual off axis and in a bounded space:

Sound pressure level (S.P.L.) from a conventional 'point source' cone loudspeaker falls off dramatically as the listener moves away from the speaker. This is more true than ever when listening 'off-axis' (i.e. not directly in front of the cone speaker). However the S.P.L. fall off from an Amina® SoundUnseen® 'diffuse source' product is much less severe with distance, especially when listening off axis. In fact, the larger the vibrating soundboard area, the greater the distance it is possible to move away from the panel (or 'source') without showing an appreciable loss in S.P.L. This is very much the case when a large part of the stud wall, or ceiling, in effect becomes the vibrating surface. Whilst most energy is generated at the surface of this product, some vibrations do pass out radially into the surrounding plasterboard surface which then, in turn, provide a small additional acoustic contribution to the room. The situation improves further when an Amina® SoundUnseen® 'diffuse source' panel is used in an acoustically reflective bounded environment (e.g. conservatory, pool area, or room containing very little soft furnishings). Here, the reflected phase incoherent energy is generally constructive, contributing to the overall S.P.L., generating a very even 'sound-fill' across a given bounded space.

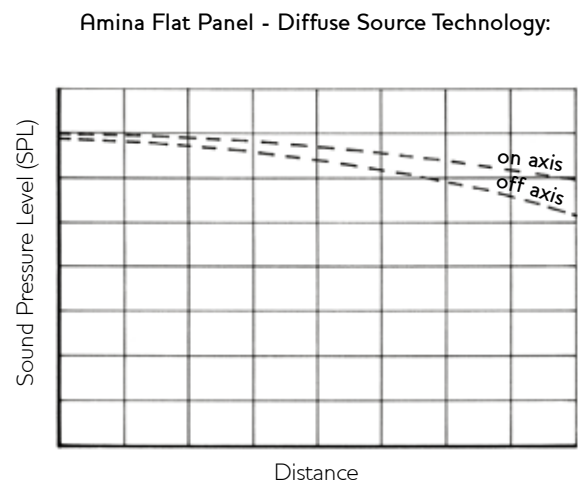
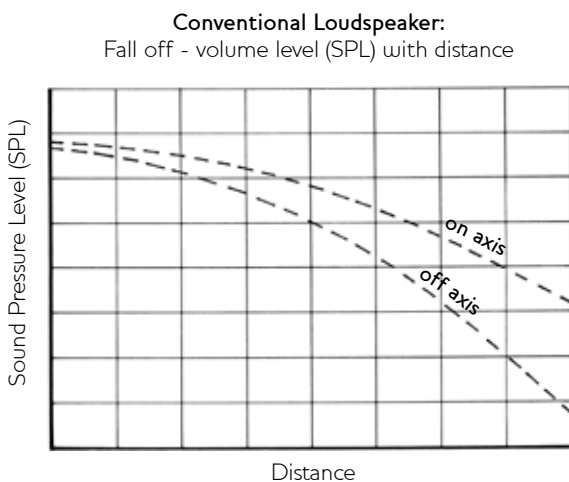

## 3 Radiated sound energy is random, diffused and highly dispersed:

Conventional cone 'point source' loudspeakers radiate sound energy that is phase related. This is analogous to the ripples formed when dropping a pebble into still water. Reflections from boundaries are highly correlated with the energy from the original source. Additions and cancellations occur helping to create a variety of problems including un-even room response, reverberation, poor intelligibility and feedback when used with open microphone channels.

The radiated sound from an Amina® SoundUnseen® 'diffuse source' panel loudspeaker is essentially random in nature, non-correlated and significantly less phase related. Reflected energy is principally constructive, creating a very even sound pressure across the entire space. Reverberation, room response and microphone feedback are typically reduced and intelligibility is generally improved over a much wider area due to the very different intermodulation effects that take place with a diffuse energy source.

## 4 Visual appearance can be matched to the surrounding decoration:

Aesthetically the concept of a thin flat panel allows greater creativity in visually disguising the product to merge into any room aesthetic. This is particularly true of the Amina® In-wall loudspeaker range, which offers zero visibility and therefore no interference with the room's interior design.

## Amina® bespoke service:

For situations where In-Wall panel loudspeakers are not appropriate, Amina® provide a special bespoke manufacturing and customisation service. Panel loudspeakers can be painted, veneered, flocked or have a laminated print (containing the image of the clients choice) mounted to its surface. Please ask your supplier for details. Amina® can also provide a full custom service, designing and making any size and shape panel loudspeakers according to client specifications.

## Applications:

Amina® In-wall loudspeakers are ideally suited for multi-room entertainment and home cinema/theatre reproduction in residential applications, and for background to foreground entertainment systems and voice reinforcement (eg. paging, retail, corporate, conferencing, hotel, restaurant, worship) in commercial premises and leisure venues. It is particularly useful (in both home and commercial premises) in wet areas, e.g. swimming pool, kitchens and bathroom ceilings, where the plaster and any surface coatings serve to isolate the Amina® In-wall loudspeaker from the humid zone. This then combines high quality sound reproduction and zero architectural visibility in humid environments whilst avoiding any long term corrosion issues.

## Product Positioning and Quantity Requirements: Home Installation

In the home environment the Amina® In-wall loudspeaker is ideal for application within stud walls or plasterboard ceilings using the supplied mounting lugs. Alternatively the loudspeaker can be mounted using the Amina® Stud Wall Back Box (not supplied), which provides additional sound proofing (see page 16 for more details).

It can also be set into solid wall structures, although this can involve considerable building work to create a suitable aperture to mount the product into. Solid wall mounting can be made easier using the Amina® Solid Wall Back Box (not supplied), please see page 16 for more details. The minimum depth of opening required in a stud wall, ceiling or solid wall, is 45mm from the wall or ceiling front surface. There is no maximum depth requirement.

In the home, the position and number of Amina® In-wall loudspeakers is generally determined by the audio format being reproduced. In a stereo listening situation, two panels will be required; in a 5.1 surround sound application, 5 panels will be required; in a 7.1 surround sound application, 7 panels. The product positioning follows the general requirements of each of those system types. One left of and one right of, and in front of or above the general listening position for stereo. One left of, one central to and one right of, and in front of the general listening position, together with one right of, and one left of and to the rear of the general listening position for 5.1 surround sound.

Of course real room layouts seldom provide ideal locations, especially considering the numerous listening or seat positions generally requiring audio coverage. The advantage of this type of 'diffuse source' loudspeaker is that the speaker location and listening position are far less critical, making them ideal for 'real' rooms.

The following schematics give a few ideas on typical positions to be adopted in stereo and 5.1 surround applications in a series of real life rooms.

Lounge system set-up:

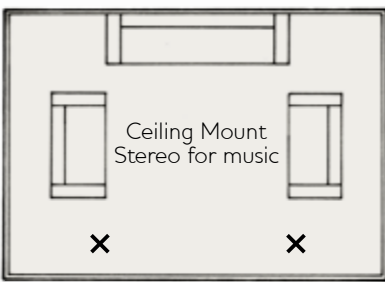
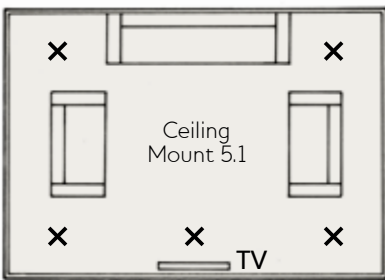

Bedroom system set-up:

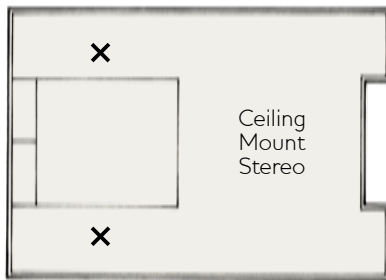
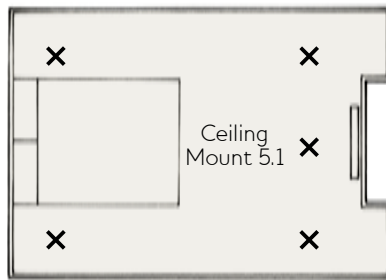

Swimming Pool room layout:

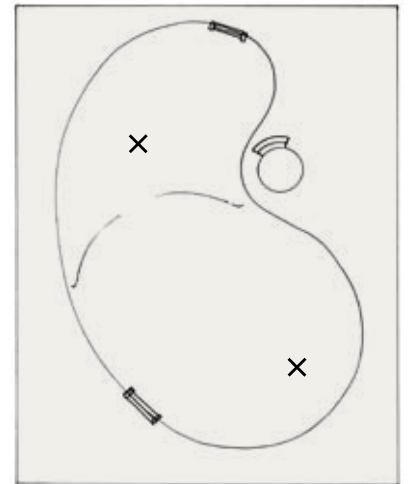

Panels positioned in ceiling above pool area

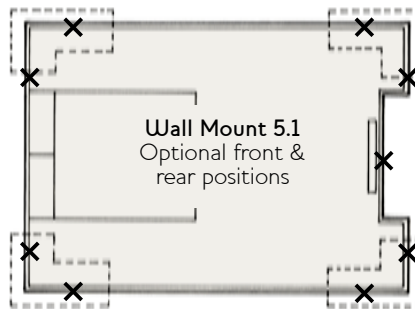
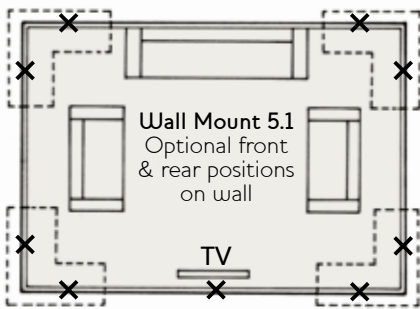

Wall Mount 5.1 & sub:  
The awkward room

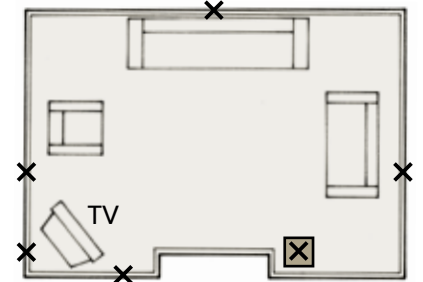

AIW units 'plastered in wall' TV screen in corner of room

**Example: 5.1 Surround Sound in the Bedroom:**

A good example to pick out here is the bedroom, with a requirement for a 5.1 surround system. Installation of any loudspeaker within a ceiling is generally very easy within a bedroom (assuming a traditional house layout), due to the ease of access through a loft void. However, the use of conventional 'point source' directional loudspeakers is likely to yield poor results as the front set of three speakers situated beyond the foot of the bed are not directionally aimed at the listener. Alternatively, applying the Amina® 'diffuse source' In-wall loudspeakers at the same positions will yield excellent results, as their non-directional qualities will place sound at the listening position even at this acute angle.

**Key**

- ✕ Amina in wall speaker
- ☒ Sub bass

## Product Positioning and Quantity Requirements: Commercial Installation

The overriding factor in terms of best product positioning for multiple source installations is, where possible, to evenly space the number of panels across the given space. This will create a very even S.P.L. across the whole environment. The orientation of the speakers is much less relevant.

As with any type of loudspeaker the quantity required in any given room depends on the following: room dimensions, where the speakers will be positioned and what performance is required from the audio system [room acoustics are also an important factor and specific installations may need specialist advice]. Amina® In-Wall loudspeakers, however, provide a much improved coverage area compared to conventional speaker types meaning that in general you will require far fewer to achieve the same level of coverage.

The most even audio coverage will be achieved by mounting speakers in the ceiling. The higher the ceiling the fewer speakers will be required to obtain good coverage. When installing in walls greater coverage can be achieved by increasing the speakers' height.

When Amina® In-Wall loudspeakers are used in rooms containing large areas of hard, reflective surfaces this only helps to enhance their excellent 'room-filling' properties.

Where high levels of speech intelligibility are needed it may be necessary to use more Amina® In-Wall loudspeakers than would be required for a simple background music system. Amina® can provide advice on speaker quantity and spacing requirements – please contact us with details of your specific installation.

If you have other special requirements please contact your supplier or Amina® for assistance.

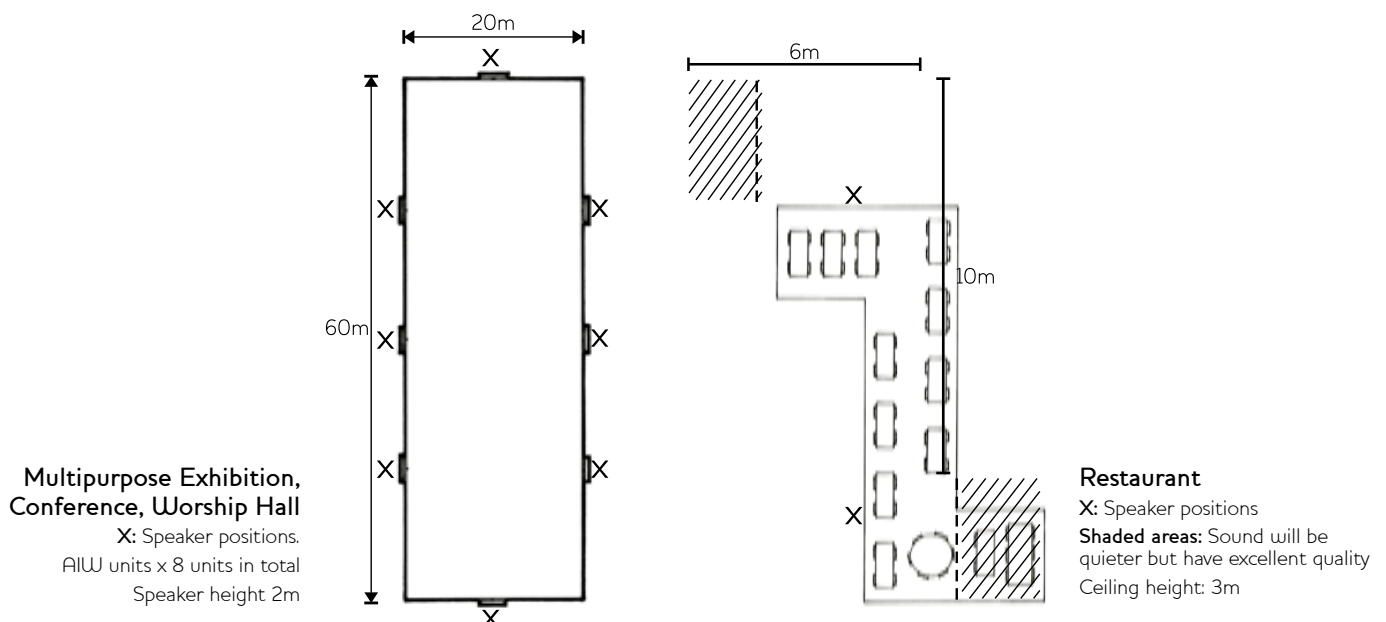

## Sound Transmission

### Sound transmission in buildings and isolation techniques:

The actual sound energy generated from the rear of the Amina® In-wall loudspeaker is equal to that generated from its front surface. Superficially this might be thought of as being trapped within the wall or ceiling and, to some extent, this is true. In practice though, some of this energy is transmitted through the rear of the wall and emerges at its opposite face or, in the case of the ceiling, emerges at the floor above. Some will also travel along any internal cavity to emerge in connecting rooms. The wall or ceiling construction will determine how much of this energy is transmitted, and users/installers need to consider carefully the impact this may have on neighbours and other building users before installation commences.

If the wall or ceiling consists of a plasterboard and studwork facing a solid concrete floor or block wall structure, sound transmission to the other side of the wall is minimal due to the heavy mass of the concrete / block structure in the centre.

If the construction, in the case of a wall, is simply plasterboard on both sides of wooden or metal stud work or, in the case of a ceiling, plasterboard faced joists with wood based floor boarding on the upper surface, then sound transmission is going to be quite considerable, due to the low mass and lack of absorptive material in between.

In these circumstances it is worth implementing additional sound isolation techniques within the wall or ceiling prior to installation of the Amina® In-Wall panel loudspeaker. At its most basic, this may be as simple as adding sound adsorbing mineral wool or wadding into the cavity directly behind the panel speaker. Different grades of such materials exist - ask your builders merchant for advice. The quality and increased depth of this material will provide improved isolation.

A more sophisticated approach is to use the Amina® Stud Wall Backbox (see page 16) as a means to absorb much of the rearward sound energy. In addition to this, a section of Acoustiblok® sound absorbing sheet could be placed within the wall cavity directly behind where the speaker is located. The ultimate in room soundproofing can be achieved with the extensive use of Acoustiblok® sheet within all the walls and ceilings of a room.

Please visit [www.acoustiblokuk.com](http://www.acoustiblokuk.com) for more advice on using this product.



Amina® Stud Wall Backbox incorporates Acoustiblok® material to enhance its sound absorption properties

Typical 'stud' wall with Sound Insulation

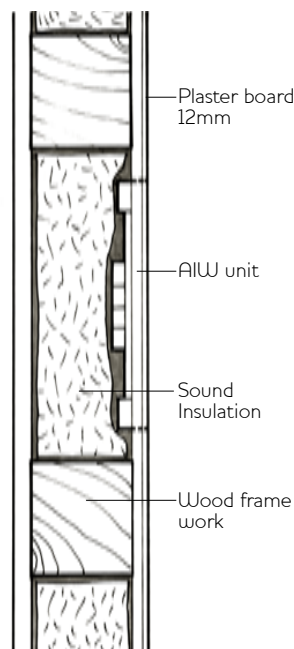

Wooden frame work/  
Plaster board front onto  
Solid block wall with  
sound insulation

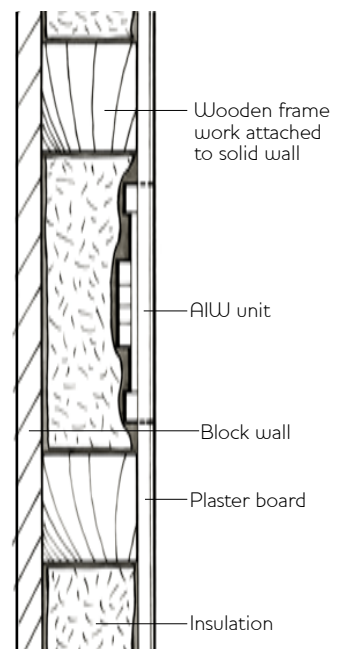

# Installing your Amina® SoundUnseen® In-wall Panel Loudspeaker:

IMPORTANT: Incorrect speaker installation could result in speaker failure. This may invalidate your warranty.  
PLEASE FOLLOW OUR INSTRUCTIONS CAREFULLY

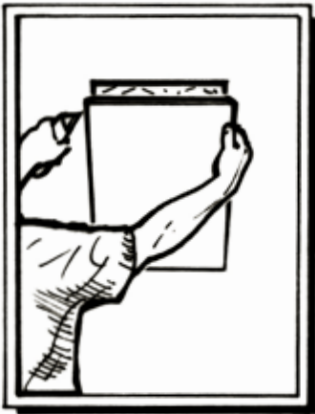

1 Create aperture

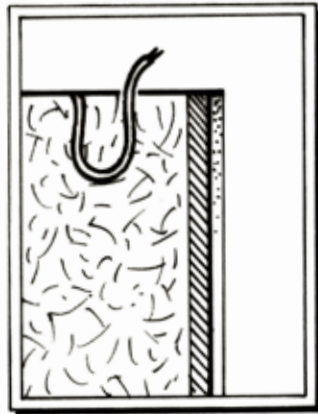

2 Pull cable  
3 Insulate cavity

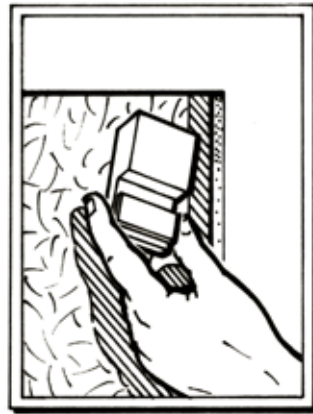

4a Fix installation lugs

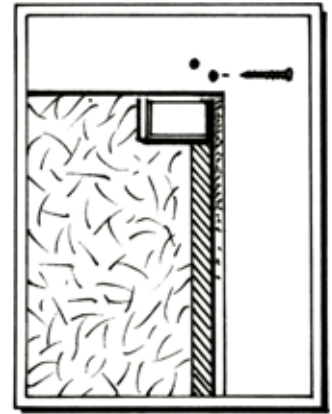

4b 4 Fix Installation Lugs

**1 Create aperture:** Using a sharp knife, cut an aperture of dimensions 450mm x 345mm, in your plasterboard wall or ceiling. This is best done using a series of shallow cuts, rather than one deep cut. Ensure the aperture is positioned in between supporting joists or stud work. We strongly advise that joists are not cut to make space for the in-wall loudspeaker. Any activity of this sort may well influence the structural integrity of your property. Special size panels are available to order should the inner joist space be smaller than this standard product. The product can be oriented in either landscape or portrait style. It can also be mounted within sloping ceiling lines.

**2 Pull cables:** Ensure all loudspeaker cables are brought to this point and check their continuity back to your source amplifier. We recommend use of a loudspeaker cable with conduction area of 1.0mm<sup>2</sup> – 2.6mm<sup>2</sup> (16 – 14 AWG). For long cable runs 2.5mm<sup>2</sup> or greater should be used.

**3 Insulate Cavity:** As per the advice given on isolation techniques (see page 11), you may find it is appropriate to add sound absorbing mineral wool or create a boxed containment section to further reduce sound transmission behind the In-wall loudspeaker. Alternatively the Amina® Stud Wall Backbox can be used (see pages 11 & 16) **Place a mineral wool layer above a ceiling mounted panel to stop debris falling on the panel's rear surface.**

**4 Fix installation lugs:** Position an installation lug under the plasterboard at each corner of your aperture. Fasten the thicker section of the lug to the underside of the plasterboard using two dry wall screws secured through the front face of the plasterboard. The thinner section of the plastic lug, with the black foam 'tensioning' tape applied, needs to be located in the corner of your aperture. The standard installation lug is designed to be used with 12.5mm thick plasterboard. If your plasterboard is a different thickness, please contact your supplier to obtain lugs to match.

**5 Locate In-Wall Loudspeaker:** Locate the In-wall panel loudspeaker in the plasterboard aperture, resting it against the four corner lugs. Connect the loudspeaker to your speaker cable. Secure the loudspeaker to the lugs using a drywall screw through the single hole in each corner of the loudspeaker's aluminium frame. Ensure the front of the In-wall loudspeaker is level with the front of your plasterboard surface by adjusting the tension on each of these four screws. Ensure the whole assembly is rigid and not loose in any way.

**6 Test Loudspeaker:** Ensure the In-wall loudspeaker is electrically connected and acoustically **tested fully before commencing plastering.** See the Installation fault finding guide later in these instructions for advice on testing.

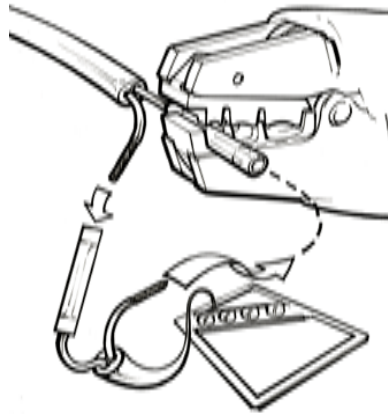

Your In-wall loudspeaker is fitted with high-quality crimp terminals. This type of connector ensures the best long-term connection for your product. Use a quality crimping tool when making your connection.

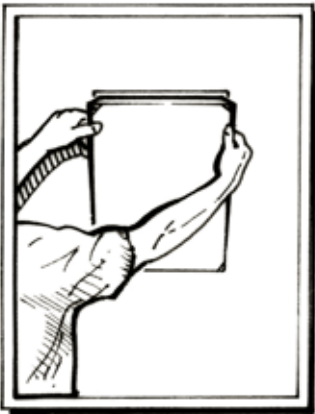

**5** Insert in-wall loudspeaker & connect speaker cable

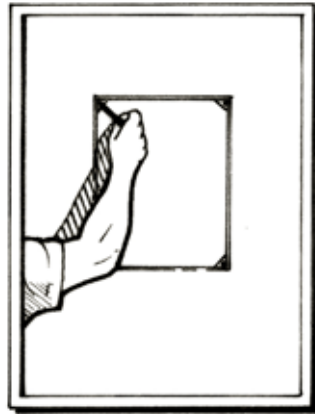

**6** Screw in and test panel loudspeaker

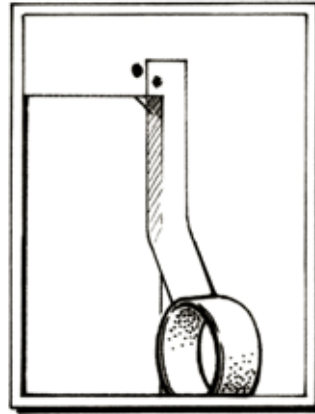

**7** Apply thin coat of PVA

**8** Apply joint tape

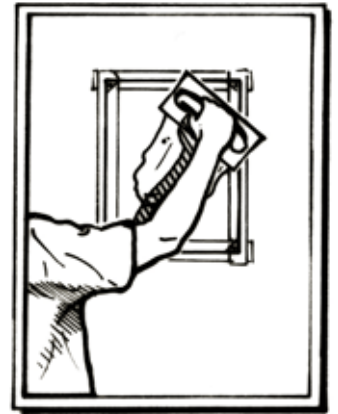

**9** Plaster

**10** Dry wall application

**11** Decorate

**7 Apply PVA to Panel:** Apply a thin coat of PVA adhesive/water mix to the entire panel surface. Use a 1 part PVA to 5 parts water mix and apply with a brush or foam roller.

**8 Apply joint tape:** Apply professional plasterboard jointing tape over the joint between panel perimeter and the plasterboard surround.

**9 Plaster:** Skim over the panel and the plasterboard (filling all edges with plaster) to create a smooth surface finish. Allow plaster to dry fully before using the In-wall loudspeaker. The best acoustic results will be achieved by keeping the plaster skim as thin as possible (1mm to 2mm is ideal.)

**10 Dry wall application & Retrofitting:** Use British Gypsum Easy-fill repair plaster or equivalent when installing this product within drywall or pre-skimmed, pre-finished walls. Set the front of the loudspeaker 2mm behind the wall or ceiling front surface. On dry walls simply skim over the loudspeaker panel surface. In a pre-skimmed wall before plastering it is necessary to carefully remove some of the existing plaster around the loudspeaker aperture. Remove enough plaster so that joint tape can be applied as per stage 8. Please note that this product is designed to have a 2mm layer of plaster over its entire surface. Its performance would be degraded if the product's surface were simply feathered into the surrounding dry wall at its edge.

**11 Decorate:** When your plasterwork is completely dry, decorate the surface of the plaster with paint, wallpaper, fabric or other coatings as required.

**12 Connect Amina® In-line Protection Unit (APU2):** Before using your In-wall loudspeaker you need to connect the APU2 between your amplifier speaker output and the loudspeaker itself. The APU2 is ideally situated near your audio system, connected on a short run of cable. The longer cable run from the In-wall loudspeaker should then be connected to the other side of the APU2. See page 12 for more details.

Only apply a finish plaster to your In-wall loudspeaker. Amina Technologies Ltd recommend British Gypsum Multi-finish and Easy-fill products. DO NOT use any type of pre-mixed plaster or filler product.

**FOR FURTHER ASSISTANCE:** Video based instructions can be viewed by visiting our web page: [www.amina.co.uk/movie/aminamovie.mpg](http://www.amina.co.uk/movie/aminamovie.mpg)

# Connecting to your amplifier/audio system:

## Amina In-line protection unit (APU2):

Your In-wall loudspeaker must be used with the supplied APU2. This device is suitable for connecting two In-wall loudspeakers. The APU2 has been designed specifically to enhance the reliability of your loudspeaker by preventing excessive drive current from your amplifier. If you attempt to overdrive your In-wall loudspeaker the APU2 will sense this and automatically reduce the volume of sound.

Only use the specific APU2 unit that is intended for your In-wall model as indicated on the APU2 case.

We do not recommend that you use amplifiers with power outputs that are far greater than the In-wall loudspeakers own power rating.

We do not recommend that you intentionally cause the APU2 to automatically protect your In-wall loudspeaker by deliberately over-driving it.

If you find that your APU2 automatically reduces the volume from your In-wall loudspeakers too frequently it may suggest that you are using an amplifier that is too powerful.



**WARNING!** Do **NOT** turn on your amplifier without both APU and AIW speaker connected. Damage may occur to your amplifier when the APU is connected to the amplifier on its own.

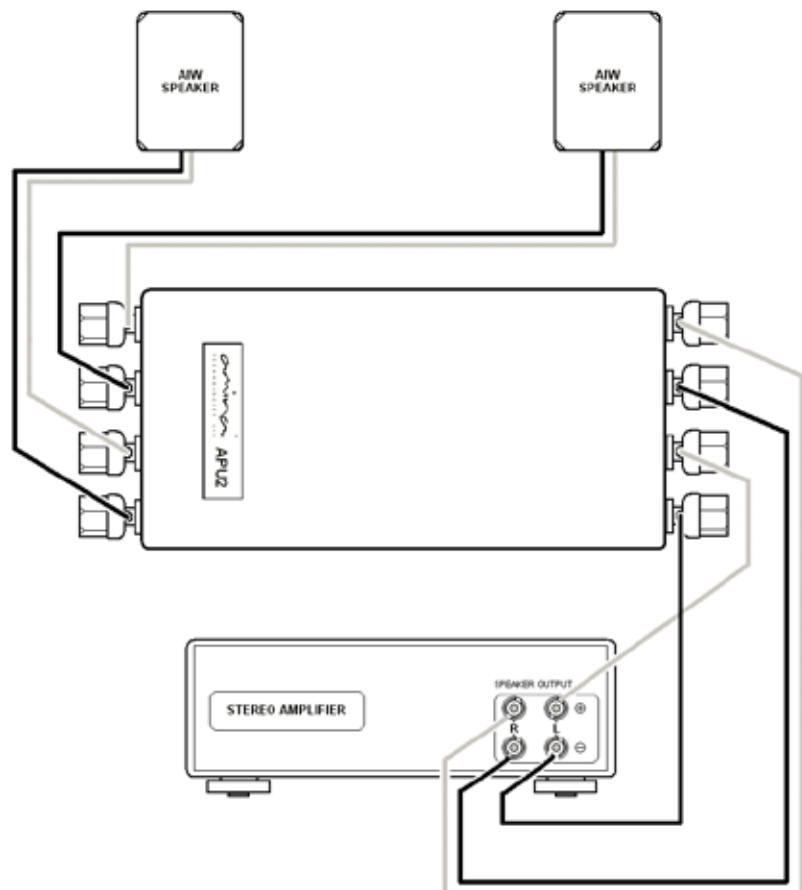

### Typical Home Theatre Set-up:

Using five or more Amina® In-wall loudspeakers you can achieve a truly immersive home cinema experience. The loudspeakers & APU2 connect to your AV amplifier in the same way as any conventional loudspeaker. We recommend you use a high quality subwoofer to reproduce the low frequency effects (LFE) realistically. AIW5's will provide the ultimate home theatre experience in any room. AIW3's are suitable for smaller rooms for more modest volume levels. We do not recommend AIW1's for home theatre use. See page 9 for suggested speaker positions in your room or follow the guidelines in your AV amplifier's instruction manual.

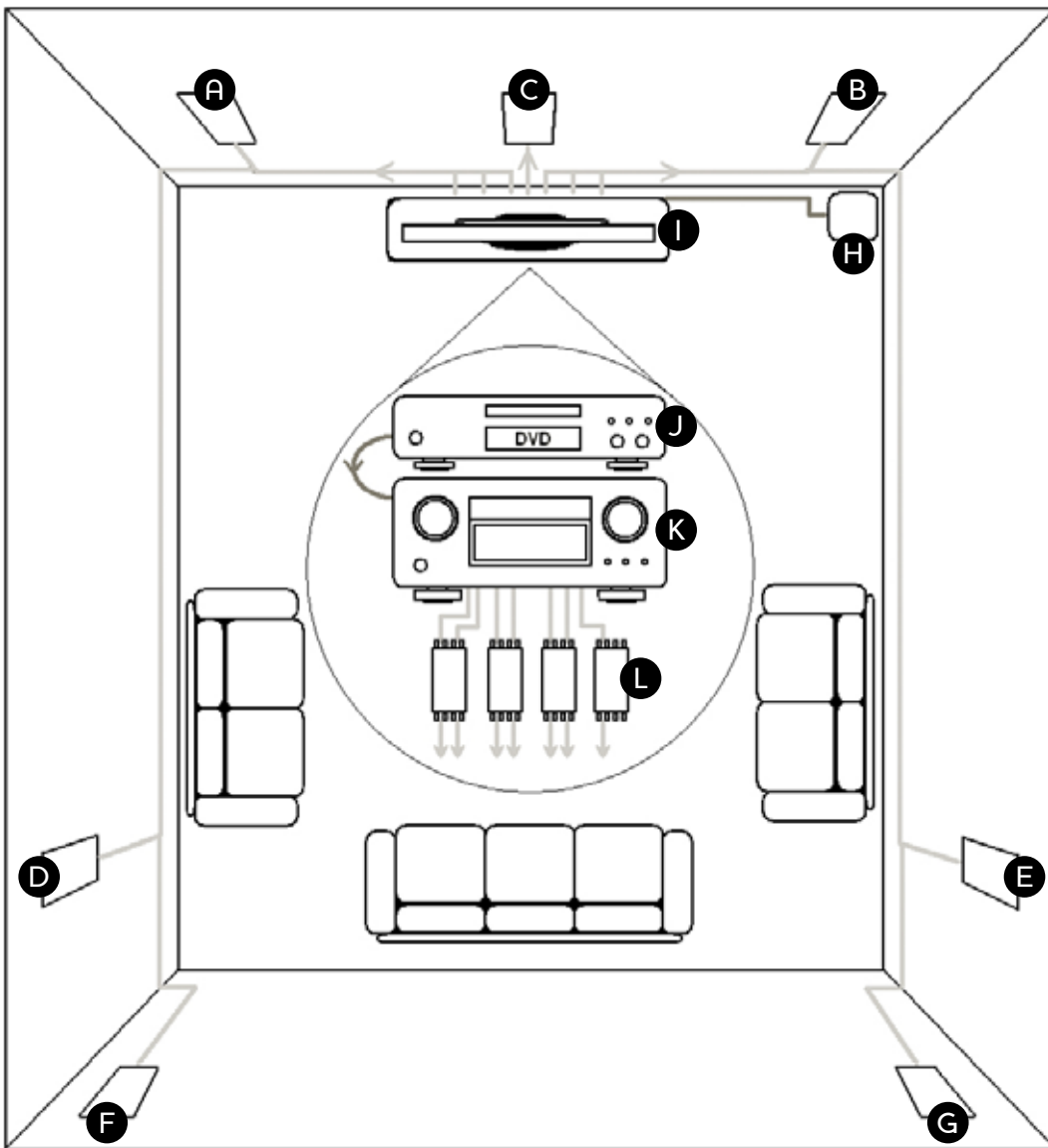

- |  |  |                                  |
|--|--|----------------------------------|
| <b>A</b> Front left In-Wall Loudspeaker      | <b>E</b> Surround right In-Wall Loudspeaker      | <b>I</b> LCD/Plasma screen       |
| <b>B</b> Front right In-Wall Loudspeaker     | <b>F</b> Surround back left In-Wall Loudspeaker  | <b>J</b> DVD Player              |
| <b>C</b> Centre/Dialogue In-Wall Loudspeaker | <b>G</b> Surround back right In-Wall Loudspeaker | <b>K</b> Multi-channel amplifier |
| <b>D</b> Surround left In-Wall Loudspeaker   | <b>H</b> Active subwoofer                        | <b>L</b> APU2 units              |

## Optional Accessories:

### Amina® Stud Wall Backbox:

Our optional aluminium back box for the installation of Amina® In-wall loudspeakers into stud walls or ceilings. The back box installs simply and provides a mounting surface for the AIW speaker to secure to. The Stud Wall Back Box also provides a consistent acoustic cavity when multiple AIW speakers are to be installed into different stud wall cavity volumes. Lining the Stud Wall Backbox is a layer of specialist sound blocking material that offers a significant reduction of rearward sound output from the loudspeaker.



### Amina® Solid Wall Back Box:

Our optional steel back box for the installation of Amina® In-wall loudspeakers into solid wall structures. The back box installs simply and provides the correct mounting surface for the In-wall loudspeaker to screw into. The Back box can be fitted into place prior to loudspeaker installation during the early stages of building works. This avoids the need to have AIW speakers in situ during heavy building works. The loudspeaker can then be installed just before the wall is plastered. Ensure joint tape is used across the speaker/wall boundary before plastering with a finish skim of 2mm plaster.



### 100v/70v Line options available:

When ordering the Amina® In-wall loudspeaker, clients can also specify 100v or 70v line versions with required power rating (This is generally only used in commercial premises). In these instances, a high quality single tap toroidal transformer is built into the loudspeaker. The specification label on the rear of the product will clearly state the power rating of the transformer. The transformer itself will be physically obvious when examining the rear of the product.



# Installation Fault Finding Guide:

It is imperative that, once the product is located into the wall or ceiling, and prior to plastering over, it is fully electrically and acoustically tested to avoid time consuming repairs or modifications at a later stage. The following guide is designed to help in determining possible problem areas, during these tests.

## No Sound Output:

Check that your audio system has power, is turned on and is working.

Check that all cables and connections are intact, and made in the proper manner.

Check for continuity over cable lengths.

Take your system back to the bare minimum (e.g. amplifier, source and speakers) to eliminate faults in other components such as filters, crossovers and equalisers.

Using an impedance meter, check the nominal impedance of the product both at the product terminals and at the amplifier end of the cable. Do these measurements match each other (allowing for the small impedance increase of perhaps less than 1 ohm, along the wire length), and do they match the stated nominal impedance on the product's specification label? If the nominal impedance does not match the products stated impedance, an exciter may have gone open or short circuit. The product will need to be returned to your supplier for repair.

If the problem persists, consult your supplier for after sales service.

## Distortion, buzzing or rattling sounds at modest volume levels:

Try to identify the location of the buzz or rattle. It may be caused by a loose screw or other mechanical fixing. Check the assembly and ensure screws and fixings are tight.

If the rattle persists, remove the panel from the wall and without any audio playing through the panel, shake the loudspeaker gently. If the rattle is evident whilst doing this, check for foreign objects (screws etc.) which may have fallen into the rear of the product and might be resting against the panel or frame. Similarly check your wiring to the product. Ensure that wires, when the product is in the final location, are not resting against the back of the vibrating panel.

Again with no audio signal applied lightly push the panel in and out at its centre. Listen carefully for rubbing voice coils on the exciter. You might hear this as a scratching sound. This may indicate that the unit has been overdriven and subsequently damaged, and needs to be returned to your supplier for repair. If the problem persists, consult your supplier for after sales service.

## Sound output is very low:

Check the depth of your plaster. It should be no more than 2mm. More than this would reduce the sound output.

Check the specification label on the back of the product. Ensure that you are not using a low impedance signal to drive a 100V line transformer based product.

With no audio signal applied lightly push the panel in and out at its centre. Listen carefully for rubbing voice coils on the exciter. This may indicate that the unit has been overdriven and subsequently damaged, and needs to be returned to your supplier for repair.

Take your system back to the bare minimum (e.g. amplifier, source and speakers) to eliminate faults in other components such as filters, crossovers and equalisers.

Using an impedance meter check the nominal impedance of the product both at the product terminals and at the amplifier end of the cable. Do these measurements match each other (allowing for the small impedance increase along the wire length), and do they match the stated nominal impedance on the product's specification label? If the nominal impedance does not match the stated impedance, an exciter may have gone open or short circuit. The product will need to be returned to your supplier for repair.

If the problem persists, consult your supplier for after sales service.

## Distortion at high volume levels:

Diffuse source panel loudspeakers of this type have an extremely fast response, articulating the signal from your electronic drive system very accurately.

Take your system back to the bare minimum (e.g. amplifier, source and speakers) to eliminate distortions introduced by other components such as filters, crossovers and equalisers.

When using your amplifier at maximum power levels, or if the input of your power amplifier is being overloaded, the signal level may be entering the 'clipping' phase. With some conventional speakers this may not be evident, but with a diffuse source panel loudspeaker this is much more likely to be reproduced in the form of distortion. Consider adjusting or upgrading your drive system.

## Feedback occurs easily with open live microphone channels:

The disperse sound wave generated by a 'diffuse source' panel loudspeaker helps generate a very even sound field in a given space. This can help reduce problems with microphone feedback. However, if you are experiencing feedback with lower gain structures please check the signal equalisation. The acoustics of your space and the reflective structures of the walls, windows, floors or ceilings may be creating acoustic standing waves within the room. Adjusting your system equalisation may help reduce feedback dramatically.

## Further details:

### Maintenance, Cleaning and Decoration:

Once the Amina® In-wall loudspeaker is plastered into a wall or ceiling it requires no physical maintenance. Your wall or ceiling can be dusted or cleaned with products appropriate to the finish (paint or wallpaper) you have finally applied to the plaster surface.

The wall or ceiling can be repainted or redecorated any number of times. Extreme care should be taken when removing wallpaper type coverings to ensure the plaster surface is not damaged or pushed in during removal and renewal of the wallpaper. If damage to the plaster work occurs, use British Gypsum Easi-fill (or similar) to repair the plaster surface prior to re-decorating. Avoid pushing in the wall or ceiling surface immediately in front of the panel loudspeaker. Excessive excursion, whilst unlikely to damage the loudspeaker, will undoubtedly crack the plaster around the perimeter of the product.

### Warranty:

This product carries a ten year manufacturers limited warranty. **(This limited warranty is dependant on the product being fitted in accordance with these instructions and being operated with the APU protection device in line with the speaker).** If it fails, please return it to your supplier. Amina® will work with your supplier to ensure any defects are repaired and your product returned to you. This statement does not affect your statutory rights.

### Reliability:

Correctly installed and used within its specification, this product is designed to give many, many years of trouble free service. As a technology, the Amina® 'diffuse source' vibrational soundboard technique has very few moving parts. Compared to a conventional moving coil loudspeaker, these movements are almost negligible. Whilst our sensitive touch sense can feel the tiny movements, they are not sufficient to be seen by the naked eye. As a consequence, the long term reliability of this electromechanical structure is enhanced.

### Removal:

If, however, a problem develops with this product, or you simply want to remove the item to change its location or move it to a new property, then it is relatively straight forward to remove it from the wall or ceiling.

By tapping the wall or ceiling, locate the In-wall loudspeaker. Take a decorator's scraper or sharp chisel. Hold the tool at an acute angle to the wall or ceiling directly over the buried panel loudspeaker. Carefully chip in to the plaster to expose a small area of the panel surface. Now hold the scraper or chisel virtually parallel to the panel and, working out to the product's edge, gently ease the rest of the plaster coat away from the panel surface. Don't worry if the panel surface receives marks or cuts during this process (it should not, however, have holes all the way through the special honeycomb panel). Once the product is plastered back in to its original or new location, the new plaster will cover all these imperfections and the product's performance will not be unduly affected.

Clear the surface plaster material from the surrounding plasterboard to expose all the joint tape covering the join between the panel and the plasterboard. Remove the joint tape and, if necessary, use a sharp knife to cut directly along the panel perimeter to free any material that may be filling the gap between the panel's edge and the surrounding plasterboard. Use a narrow chisel or flat blade screw driver to remove the plaster or other filler material to expose the screws at each corner of the product. Using a suitable screwdriver, remove the four screws holding the product in position. Ease the product from the wall or ceiling and disconnect the loudspeaker cable, leaving the fixing lugs in their corner positions.

If the product needs repairing, please return it to your supplier, or Amina® directly, for a rapid turn around repair. Once repaired the product can be re-affixed into position following the installation steps detailed above. Ensure new joint tape is used over the join between the panel and surrounding plasterboard and use Easi-fill to plaster over the panel and immediate surrounding area. Once dry, sand down and use a wet sponge to create a flat surface, level with the original surrounding plasterwork.

Alternatively if the product is to be moved to a new location or property, you need to make good the opening in your plasterboard wall or ceiling. Carefully remove the fixing lugs and replace them with simple flat rectangular wooden battens of similar size, in the similar location to the previous lugs. In the space left by the panel, fit a sheet of plasterboard (cut to size 450mm x 345mm), attaching it with dry wall screws to the wooden corner battens. Apply joint tape to the perimeter join and use Easi-fill to plaster over the new plasterboard section and immediate surrounding area. Once dry, sand down and use a wet sponge to create a flat surface, level with the original surrounding plasterwork.

Re-use the old fixing lugs to fit the product into the new location using the procedure detailed in the Installation section above. If you need new fixing lugs please contact Amina® for spares stating the thickness of plasterboard the unit is to be fitted to, and your product serial number (noted on the back of the product).

## Specifications:

Model:	AIW1X	AIW2X	AIW3X	AIW4X	AIW5X
Description:	In-Wall loudspeaker	Dual input In-Wall loudspeaker	In-Wall loudspeaker	Dual input In-Wall loudspeaker	In-Wall loudspeaker
Product Dimension:	450 x 345 x 38mm	450 x 345 x 38mm	450 x 345 x 38mm	450 x 345 x 38mm	450 x 345 x 38mm
Product Weight:	1.00Kg	1.13Kg	1.13Kg	1.76Kg	1.76Kg
Active Panel Material:	Resin reinforced paper skins, aluminium honeycomb core	Resin reinforced paper skins, aluminium honeycomb core	Resin reinforced paper skins, aluminium honeycomb core	Resin reinforced paper skins, aluminium honeycomb core	Resin reinforced paper skins, aluminium honeycomb core
Fixings:	Four PVC plastic mounting lugs for 12.5mm plasterboard (other thicknesses available)	Four PVC plastic mounting lugs for 12.5mm plasterboard (other thicknesses available)	Four PVC plastic mounting lugs for 12.5mm plasterboard (other thicknesses available)	Four PVC plastic mounting lugs for 12.5mm plasterboard (other thicknesses available)	Four PVC plastic mounting lugs for 12.5mm plasterboard (other thicknesses available)
Electrical Connection:	Twin blue butt-splice crimp terminal (suitable for 1.5mm <sup>2</sup> to 2.5mm <sup>2</sup> cable diameter)	Twin blue butt-splice crimp terminal (suitable for 1.5mm <sup>2</sup> to 2.5mm <sup>2</sup> cable diameter)	Twin blue butt-splice crimp terminal (suitable for 1.5mm <sup>2</sup> to 2.5mm <sup>2</sup> cable diameter)	Twin blue butt-splice crimp terminal (suitable for 1.5mm <sup>2</sup> to 2.5mm <sup>2</sup> cable diameter)	Twin blue butt-splice crimp terminal (suitable for 1.5mm <sup>2</sup> to 2.5mm <sup>2</sup> cable diameter)
Nominal Impedance:	8Ω	8Ω + 8Ω	8Ω	8Ω + 8Ω	8Ω
Minimum Impedance:	5Ω with In-line Protection Unit connected	5Ω with In-line Protection Unit connected	5Ω with In-line Protection Unit connected	5Ω with In-line Protection Unit connected	5Ω with In-line Protection Unit connected
Power Rating (In-Line Protection Unit must be connected):	20W	20W + 20W	40W	40W + 40W	80W
Protection Filter requirement:	Amina AIW1X In-Line Protection Unit APU2	Amina AIW2X In-Line Protection Unit APU2	Amina AIW3X In-Line Protection Unit APU2	Amina AIW4X In-Line Protection Unit APU2	Amina AIW5X In-Line Protection Unit APU2
Frequency Range (-6dB):	100Hz - 20kHz	100Hz - 20kHz	100Hz - 20kHz	100Hz - 20kHz	100Hz - 20kHz
Sensitivity:	82dB at 1m/1W [assuming 1mm/2mm plaster thickness]	85dB at 1m/1W with both channels driven [assuming 1mm/2mm plaster thickness]	85dB at 1m/1W [assuming 1mm/2mm plaster thickness]	88dB at 1m/1W with both channels driven [assuming 1mm/2mm plaster thickness]	88dB at 1m/1W with both channels driven [assuming 1mm/2mm plaster thickness]
Maximum SPL:	95dB at 1m/20W [assuming 1mm/2mm plaster thickness]	101dB at 1m/20W per channel with both channels driven [assuming 1mm/2mm plaster thickness]	101dB at 1m/40W [assuming 1mm/2mm plaster thickness]	105dB at 1m/40W per channel with both channels driven [assuming 1mm/2mm plaster thickness]	105dB at 1m/80W [assuming 1mm/2mm plaster thickness]

We wish you many happy hours of delightful listening to this unique audio product. If you have any questions or comments, or need any help or advice, we would be delighted to hear from you by phone, letter or email using the contact details opposite.

At the end of its useful life, and in compliance with the European directive on waste electrical and electronic equipment (WEEE), this product is to be returned to your supplier, or directly to Amina for recycling. If you have any questions please call Amina for assistance.



This document is Copyright of Amina Technologies Ltd, 2008  
Easi-fill is a trademark of British Gypsum Ltd  
Amina® is a registered trademark of Amina Technologies Ltd  
SoundUnseen® is a registered trademark of Amina Technologies Ltd

### Customer Services

Amina Technologies NA Ltd  
Loveland  
Ohio  
OH 45140  
USA  
Toll Free **+866.GO.AMINA**  
**(866.462.6462)**

T **+001 513 677 1880**  
F **+001 513 677 8464**

### Customer Services

Amina Technologies Ltd  
Cirrus House  
Glebe Road  
Huntingdon  
Cambridgeshire  
PE29 7DX

T **+44(0)1480 354390**  
F **+44(0)1480 356564**  
E **inspired@amina.co.uk**  
W **www.amina.co.uk**



INSTRUCTION GUIDE



*"sound has never looked so good"*



Amina Technologies NA Ltd  
(USA Division)  
Loveland  
Ohio  
OH 45140  
USA  
Toll Free +866.GO.AMINA  
(866.462.6462)  
T +001 513 677 1880  
F +001 513 677 8464

Amina Technologies NA Ltd  
(Canada Division)  
286 Columbus Road East  
Oshawa, Ontario  
Canada  
L1H 7K4  
T (001) 905 655 6411  
F (001) 888-329-2491  
E sales@aminatechnologies.com  
W www.aminatechnologies.com

Amina Technologies Ltd  
Cirrus House  
Glebe Road  
Huntingdon  
Cambridgeshire  
PE29 7DX  
T+44(0)1480 354390  
F+44(0)1480 356564  
E inspired@amina.co.uk  
W www.amina.co.uk