

Connecting 6000-series electric track

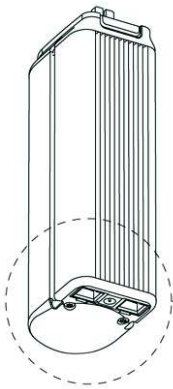

- > 6200/ 6300 /6302/ 6500
- > DIN Power supplies
- > for operation using:
 - momentary switch
 - relais

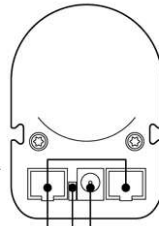

1 x connector for 24V DC power plug

- > coaxiale power plug
- > 'center positive'
- > min. 22V
- > max. 28V
- > 2,1 x 5,5 x 10-11 mm

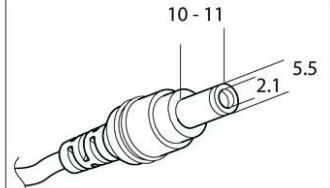

DIN Power Supplies	P [W]	DIN Power Supplies	P [W]
6030-DR-075	75W	6030-DR-240	240W
6030-DR-120	120W	6030-DR-480	480W

Rail type	P *)	max. cable length per diameter		
		0,75mm ²	1 mm ²	1,5 mm ²
6200 straight	36W	30m	40m	60m
6200 1x bend	48W	22m	30m	45m
6200 2x bend	60W	18m	24m	36m
6302	20W	56m	75m	112m
6300	12W	90m	120m	180m

*) medium weight curtain, 'room' height, glider 4010, no heading

2 x connector for RJ45 plug:

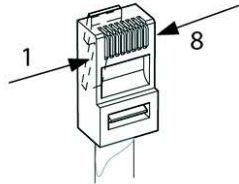
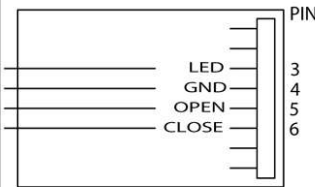

connect wires necessary only

LED

Schakeleigenschaften

0	Open and close should not be activated simultaneously. If so, the motorunit will switch to the programming mode;	0	Bounce time lower than 0,04 sec required.
0	pulse < 1,2 sec: - automatic complete open/close - stop	0	The switching current is +/- 5,5mA;
0	pulse > 1,2 sec: the system runs untill button is released	0	24V out pin2 and pin4: max. 2,4VA
		0	Potential free switching only

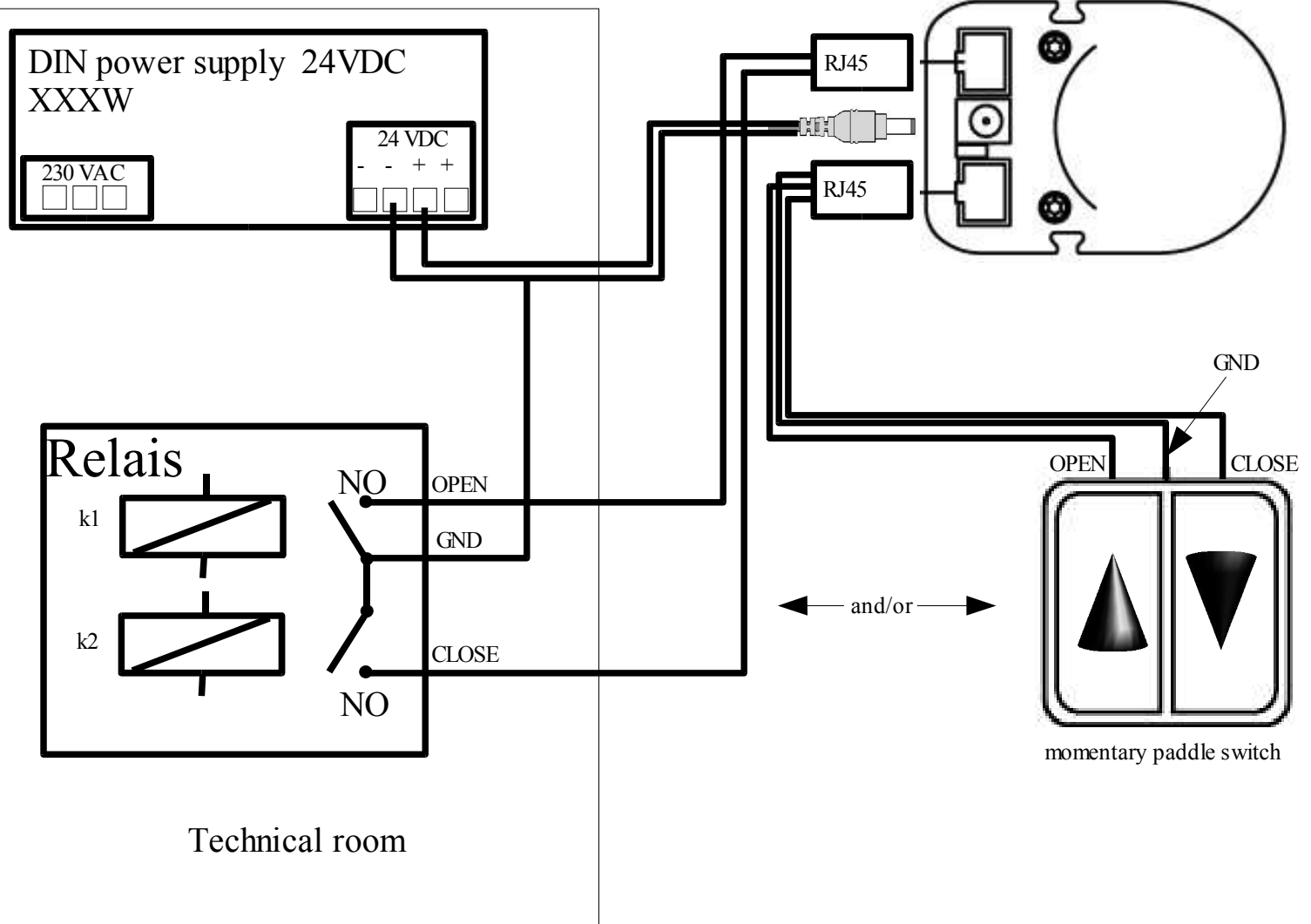

Technical room

momentary paddle switch